

Measurements of the Nonlinear Coefficient of Standard SMF, DSF, and DCF Fibers Using a Self-Aligned Interferometer and a Faraday Mirror

C. Vinegoni, M. Wegmuller, and N. Gisin

Abstract—Using a method based on the detection of the Kerr phase shift by a self-aligned interferometer, we present measurements of the nonlinear coefficient n_2/A_{eff} for standard single-mode fiber (SMF), dispersion-shifted fibers, and dispersion compensating fibers. The presence of a Faraday mirror in the interferometer makes the setup very robust, and different test fibers can be measured without any further readjustments. Interlaboratory comparisons show that the values found with our method are in good agreement with the other ones. Further, analysis of a SMF fiber with large chromatic dispersion shows a good reproducibility of the n_2/A_{eff} measurements as a function of fiber length.

Index Terms—Nonlinear optics, optical fiber measurements, optical Kerr effect.

I. INTRODUCTION

THE IMPLEMENTATION of erbium-doped fiber amplifiers and chromatic dispersion compensation allows for long distance data transmission. Along with the technique of wavelength-division multiplexing (WDM), this leads to an important amount of power inside the fiber over long distances, and optical nonlinearities start to play a significant role. Their magnitudes depend on the ratio n_2/A_{eff} , where n_2 is the nonlinear refractive index of the fiber and A_{eff} the effective area of the mode. There are different methods to measure n_2/A_{eff} , based on self-phase modulation (SPM) or cross-phase modulation (XPM) induced phase shift detection [1] using interferometric and noninterferometric schemes. The interferometric detection scheme [2] presents the advantage that it can be implemented more easily, but a disadvantage is its susceptibility to environmental perturbations that leads to a poor stability. In our setup, we obtained a considerable improvement of this technique by using a self-aligned interferometer [3] with a Faraday mirror. This method has the advantage to be simple and all-fiber implementable. The fluctuations due to the environmental perturbations are completely removed [4].

In this letter, after giving a brief description of our measurement method, we compare the values of n_2/A_{eff} obtained with

our method for dispersion-shifted fibers (DSF), dispersion compensating fibers (DCF), and a standard single-mode fiber (SMF) with the ones obtained by other institutions on the same fibers. Our values are found to agree quite well with the results from the different measurement methods employed by the other institutions. Moreover, we demonstrate that our results are independent of the length of the test fiber (on a 10-km range) even in the presence of large (17 ps/nm · km) group velocity dispersion (GVD), which cause some problems in other measurement methods [5].

II. PRINCIPLE OF OPERATION

Due to the power dependence of the refractive index, a pulse with peak power P and wave number k , traveling along a fiber of length L , will acquire a power dependent phase change ϕ given by

$$\phi(P) = \phi_l + \phi_{nl} = n_0 k L + k L_{\text{eff}} \frac{n_2}{A_{\text{eff}}} P m \quad (1)$$

The fiber losses are accounted for by the effective length $L_{\text{eff}} = 1/\alpha[1 - \exp(-\alpha L)]$, with fiber loss coefficient α [1]. The polarization parameter m depends on the polarization characteristics of the test fiber and the input signal polarization state. It is equal to one for the case of a polarization maintaining fiber if the light is coupled into one of the two axes. For the case of a sufficiently long standard telecom fiber with a complete scrambling of the polarization, it was demonstrated that $m = 8/9$ [6]. Using (1), a measure of the acquired phase shift allows to determine the ratio n_2/A_{eff} (or, through an independent measurement of A_{eff} , the value of n_2).

The setup of the self-aligned interferometer is shown in Fig. 1 and is described in detail in [4]. High peak power pulses (pulse length 20 ns) from an erbium-doped fiber amplifier (EDFA) are split at the entry of the first coupler (coupling ratio 50/50) and move along the two different arms of the interferometer. These arms are different in length such that the two pulses do not interfere when they recombine at the second coupler (coupling ratio 90/10). Due to the asymmetry of the last coupler, the two pulses enter the fiber under test (FUT) with different powers, and according to (1), they will acquire different amounts of phase shift during the propagation along the FUT. The pulses are then reflected at the Faraday mirror (FM) and return back through the

Manuscript received June 13, 2001; revised August 8, 2001. This work was supported by the Swiss Federal Office for Education and Sciences (OFES) in the framework of the European COST 265 action.

The authors are with the Group of Applied Physics, University of Geneva, CH-1211 Geneva 4, Switzerland (e-mail: claudio.vinegoni@physics.unige.ch).

Publisher Item Identifier S 1041-1135(01)09495-2.

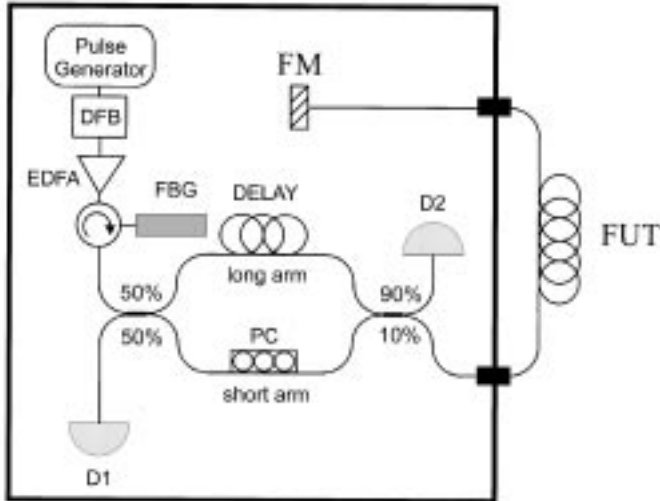

Fig. 1. Experimental setup of the self-aligned interferometer. DFB. EDFA. PC. FUT. FM. D detector. FBG.

FUT and the interferometer, toward the first coupler. During the go and return trip through the interferometer, four different paths are possible. A double pass of the long-arm (LL), of the short-arm (SS), and a forward pass of the short (long) arm with a return pass through the opposite arm (SL and LS, respectively). Due to the difference in arm lengths, three different arrival times at detector D1 can be distinguished. Only the middle pulse arising from the interference between the SL and the LS pulses is further analyzed. The power of this pulse depends on the phase relationship between the two interfering signals and can be exploited to calculate the nonlinear phase shift experienced in the FUT. Note that contrary to regular Mach-Zehnder interferometers, the balancing of the interferometer arms is not critical here as the path lengths of the two interfering signals are automatically matched (self-aligned).

It is possible to show [4] that in order to have the maximum visibility at the exit of the interferometer (i.e., the pulses have the same state of polarization), the polarization controller (PC) inserted in one of the interferometer arms has to be adjusted such that the transfer matrix of the short arm is equal to the transfer matrix of the long one. Note that using a standard mirror in place of the FM, an additional PC would be required [4], making the initial adjustment of the interferometer more difficult. Moreover, both PCs would have to be readjusted for every new FUT. With the FM instead, the interferometer does not require any adjustments after its initial calibration.

In our measurement, the PC was adjusted once for all such that all the light was directed toward detector D1, when no nonlinearity is present (i.e., no FUT is present and at low input power). The detected power P_{OUT} at the exit of the interferometer then becomes

$$P_{OUT}(P) \propto P \cos^2(\Delta\phi) \quad (2)$$

where P corresponds to the pulse power at the entry of the coupler, and $\Delta\phi$ corresponds to the nonlinear phase shift acquired along a double pass of the FUT [4]

$$\Delta\phi(P) = \frac{2\pi}{\lambda} PL_{eff} \frac{16}{45} \frac{n_2}{A_{eff}}. \quad (3)$$

TABLE I

VALUES OF THE NONLINEAR COEFFICIENT n_2/A_{eff} FOR DIFFERENT TEST FIBERS MEASURED WITH THE METHOD PROPOSED IN THIS LETTER (COLUMN A) AND AS MEASURED BY OTHER INSTITUTIONS (COLUMN B). FOR THE VALUES MEASURED WITH OUR METHODS, THE MAXIMUM ABSOLUTE DEVIATION FROM THE AVERAGE (MD) IS USED TO CHARACTERIZE THE REPRODUCIBILITY

Fiber	Length (m)	λ_0 (nm)	A_{eff} (μm^2)	Nonlinear Coefficient $n_2/A_{eff} \times 10^{-10} \text{ W}^{-1}$			
				A		B	
				Value	MD	Value	SD
G-1 (SMF)	11840	1302	-	3.6	5%	-	-
DSF-1 (DSF)	1990	1556.4	44.5	6.4	2%	6.3 [7]	5% [7]
DSF-2 (DSF)	1990	1548.6	41.1	6.3	5%	6.6 [7]	5% [7]
NIST-B (DSF)	1563	-	52.2 [9]	4.3	2%	4.3 [9]	14% [9]
NIST-C (DCF)	1010	-	20.2 [9]	15.6	11%	13.4 [9]	15% [9]

For the values measured at NTT [7] the standard deviation is shown. For the values obtained by the NIST round robin [9] the standard deviation among different participants is reported

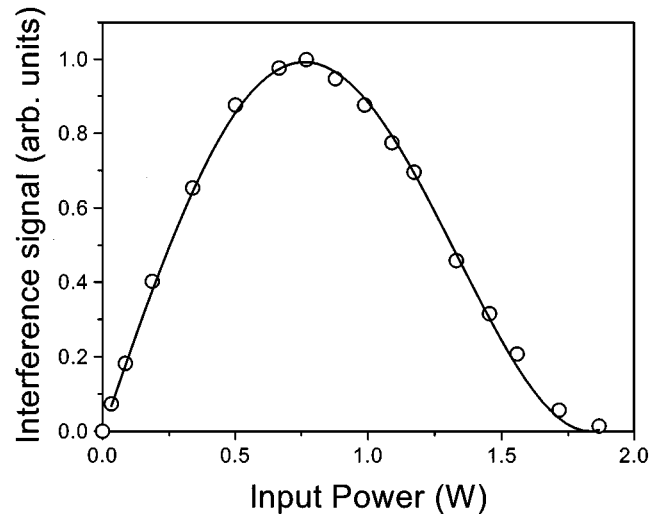

Fig. 2. Detected interference signal power as a function of launch power: (open circles) measured data, (solid line) theoretical fit (2).

Detector D2 is used to measure the power at the entry of the FUT.

III. RESULTS

n_2/A_{eff} was measured for five different fibers comprising SMF, DSF, and DCF of different lengths. The fibers' parameters are listed in Table I.

Fibers DSF-1 and DSF-2 were also measured at NTT [7] utilizing the SPM-based continuous-wave (CW) dual-frequency (DF) method [5], [8]. Fibers NIST-B and NIST-C were measured by six different institutions using the CWDF method and the pulsed method using different fiber lengths and laser wavelengths. Results regarding this North American round robin were published in [9].

A typical result for a single measurement with our method is shown in Fig. 2. The FUT was Fiber G-1 with a fiber length of 2231 m. The interference signal power detected at the exit of the interferometer is plotted as a function of the launch input power P . The experimental values (open circles) are increasing almost linearly in the beginning, demonstrating that nonlinear effects are of little importance up to launched powers of about 0.5 W. Then they set in quite heavily, and the measured power eventually starts to decrease with increasing launch power. The

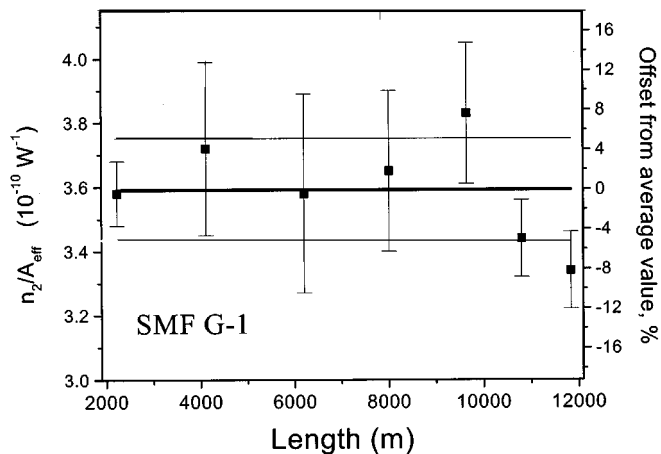

Fig. 3. Nonlinear coefficient measured for different lengths of the same fiber (G-1).

maximum of the interference signal power is reached at a launch power of 0.8 W, whereas a null value, corresponding to a full $\pi/2$ nonlinear phase shift, is obtained for 1.9 W. From this value, n_2/A_{eff} can be calculated using (3). However, we always fitted all the points as the precision is much better.

For each fiber, three to four different measurements were taken on different days in order to test the reproducibility of our method. The corresponding results are summarized in column A of Table I. Note that the maximum absolute deviation from the average (MD) is used to characterize the reproducibility. Generally, the reproducibility is quite good ($<10\%$) although it varies somewhat from fiber to fiber (see Table I). Column B of Table I reports the values found by the other laboratories. For the NIST fibers [9], the standard deviation among the n_2/A_{eff} values of the six different round robin participants is given. As one can see the agreement with our values is quite good (with a deviation $<15\%$ in the worst case). For the NTT fibers [7], the standard deviation of different measurements (using the same measurement method) is given. Once more, the agreement with our values is good ($<5\%$). For all measurements of both the NIST and NTT comparison, the deviation of our values are within the error bars.

When looking at the maximum deviation of our measurements, it is striking that for the NIST-C fiber the value is much larger. A reason for this might be that the GVD in this DCF fiber is much higher. In fact, some methods [5] were found to be very sensitive to the fiber's length for large values of the chromatic dispersion. Therefore, it is interesting to analyze the reproducibility of our method in a large GVD fiber as a function of the fiber length.

Consequently, we made cutback measurements of n_2/A_{eff} for a SMF (G-1) changing the length from 12 to 2 km. For each length, at least three measurements were taken. The results are reported in Fig. 3. The overall standard deviation is only 6%,

i.e., a similar amount as the maximum fluctuations for a fixed length (see Table I). Also, no trend of the n_2/A_{eff} values as a function of fiber length can be found, demonstrating that our method is insensitive to the fiber length (in a range of around 10 km) even for large values of chromatic dispersion.

IV. CONCLUSION

In this letter, we have presented a simple and stable method for the measurement of the nonlinear coefficient n_2/A_{eff} based on an all-fiber self-aligned interferometer. Due to its robustness against environmental perturbations, and its ease of adjustment, the proposed method is well suited to routinely measure the nonlinear coefficient. The presence of the FM allows to easily exchange the FUT without necessitating any further readjustments of the interferometer.

An interlaboratory comparison of the n_2/A_{eff} measurements on the same test fibers showed good agreement of our results with the others. Moreover, our method seems to be independent of the fiber's length on a range of 10 km even in the presence of large GVD, known to cause problems with some of the other measurement methods.

ACKNOWLEDGMENT

The authors would like to thank K. Nakajima and N. Ohashi from NTT, A. Pham from EXFO, C. Meneghini from INO and T.J. Drapela from NIST for providing us the test fibers.

REFERENCES

- [1] G. Agrawal, *Nonlinear Fiber Optics*. San Diego, CA: Academic, 1989.
- [2] F. Wittl, J. Vobian, G. Herchenroeder, and W. Dultz, "Interferometric determination of the nonlinear refractive index n_2 of optical fibers," in *Tech. Dig.—Symp. Optical Fiber Measure., (NIST SP 905)*, 1996, pp. 71–74.
- [3] J. Meier, "Stabile Interferometrie des Nichtlinearen Brechzahlkoeffizienten von Quarzglasfasern der Optischen Nachrichtentechnik," Ph.D., 1995.
- [4] C. Vinegoni, M. Wegmuller, and N. Gisin, "Determination of the nonlinear coefficient n_2/A_{eff} using a self-aligned interferometer and a Faraday mirror," *Electron. Lett.*, vol. 36, pp. 886–888, 2000.
- [5] T. Omae, K. Nakajima, and M. Ohashi, "Universal conditions for nonlinear refractive index n_2 estimation of dispersion compensating fibers by cw-SPM method," in *OFC 2001*, Anaheim, 2001.
- [6] S. V. Chernikov and J. R. Taylor, "Measurement of normalization factor of n_2 for random polarization in optical fibers," *Opt. Lett.*, vol. 21, pp. 1559–1561, 1996.
- [7] C. Vinegoni, M. Wegmuller, N. Gisin, K. Nakajima, and M. Ohashi, "Interlaboratory measurements of the nonlinear coefficient of standard SMF and DSF fibers using an interferometric method and an SPM based cw dual-frequency method," in *OFMC 2001*, Cambridge, U.K.
- [8] A. Boskovic, S. V. Chernikov, J. R. Taylor, L. Gruner-Nielsen, and O. A. Levring, "Direct continuous-wave measurement of n_2 in various types of telecommunication fiber at 1.55 μm ," *Opt. Lett.*, vol. 21, pp. 1965–1967, 1996.
- [9] T. Drapela, "Effective area and nonlinear coefficient measurements of single-mode fibers: recent interlaboratory comparison," *Proc. SPIE, ser. Applications of Photonic Technology 4*, vol. 4087, pp. 293–297, 2000.